



बैंक नोट पेपर मिल इण्डिया प्रा. लिमिटेड

BANK NOTE PAPER MILL INDIA PVT LIMITED

JV of SPMCIL - A Govt. of India Enterprises & BRBNMPL - A Subsidiary of RBI

Email : sanjeev.kunal@bnpmindia.com, Ph: 0821 - 2401 144

LIMITED TENDER ENQUIRY No: BNPM/LTE/HC/223/2018-19

Issue Date: 20.06.2018

Closing Date: 29.06.2018

1. Scope of work:

Supply of Shaft Puller Hydraulic Cylinder along with complete set of Seals and Bale Press Hydraulic Cylinder along with complete set of seals (Total 08 items) as per the specifications mentioned in the description.

2. Terms & Conditions:

S. No.	Particulars	Details
1.	Payment Terms	100% within 30 days on receipt and acceptance of goods at BNPM Plant, Mysuru and on production of all required documents by the supplier. <u>Warranty certificate and NEFT/RTGS details shall be furnished mandatorily along with the Invoice.</u>
2.	Price	Price should be inclusive of taxes
3.	Freight	Shall be included in quoted price.
4.	Packing & Forwarding	Shall be included in quoted price.
5.	Delivery Terms	FOR Basis, Bank Note Paper Mill India Private Limited, Mysuru
6.	Warranty Period	12 Months, Warranty certificate to be provided
7.	Warranty Certificate	Applicable / Not Applicable
8.	Delivery Period (in days/ weeks)
9.	Material to be delivered at	Engineering Stores Bank Note Paper Mill India Private Limited Note Mudran Nagar Mysore 570 003
10.	Contact person in Engineering Stores	Mr. Ashutosh Kumar 0821- 2401 486 Mr. Sunil Kumar 0821- 2401 485



3. Price Bid Format:

S. No.	Description	Qty.	UOM	Unit price (Rs.)	P&F, Insurance & Freight Charges (Rs.)	GST @	Unit price including P&F, Insurance, Freight & GST (Rs.)	Total price inclusive of P&F, Freight, Insurance & GST (FOR, BNPM, Mysuru) (Rs.)
1.	Shaft Puller Clamp Hydraulic Cylinder Size: 63 X 40 X 160mm As per Drg no. BNPM/FH/039/2017-18	1	No.					
2	Complete Set of Seals for Clamp Hydraulic Cylinder as per Drg no. BNPM/FH/039/2017-18	1	Set					
3	Shaft Puller Main Hydraulic Cylinder Size: 63 X 40 X 850mm As per Drg no. BNPM/FH/040/2017-18	1	No.					
4	Complete Set of Seals for Main Hydraulic Cylinder as per Drg no. BNPM/FH/040/2017-18	1	Set					
5	BALE PRESS RAM Hydraulic Cylinder Item: RAM Hydraulic Cylinder as per Drg no. BNPM/FH/041/2017-18	1	No.					
6	Complete Set of Seals for RAM Hydraulic Cylinder as per Drg no. BNPM/FH/041/2017-18	1	Set					



7	BALE PRESS Hydraulic Cylinder Item: Bale Press Compact Cylinder as per Drg no. BNPM/FH/042/2017-18	1	No.					
8	Complete Set of Seals for Compact Cylinder as per Drg no. BNPM/FH/042/2017-18	1	Set					
Grand total price inclusive of P&F, Insurance, Freight & GST (INR)								

Note:

1. Successful bidder shall visit BNPM Plant, Mysuru to understand the requirement and take final dimensions of the cylinders mentioned above before initiating manufacturing of goods.
2. Successful bidder shall submit drawings for the tendered products for approval before initiating manufacturing of goods.
3. Pressure test certificate to be mandatorily submitted by the successful bidder along with supplies.
4. L-1 status will be arrived based on overall price i.e. all the 08 items will be considered together to determine lowest bidder.
5. Arbitration, Jurisdiction & Force Majeure clause will be applicable as per BNPM terms.

We hereby confirm that

1. We accept all terms & conditions mentioned in the enquiry.
2. Price quoted is inclusive of all taxes, P&F, freight etc. on FOR Basis, BNPM, Mysuru
3. HSN Code:

Signature of bidder:

Name of the Firm:

Seal of the firm:

GST No:



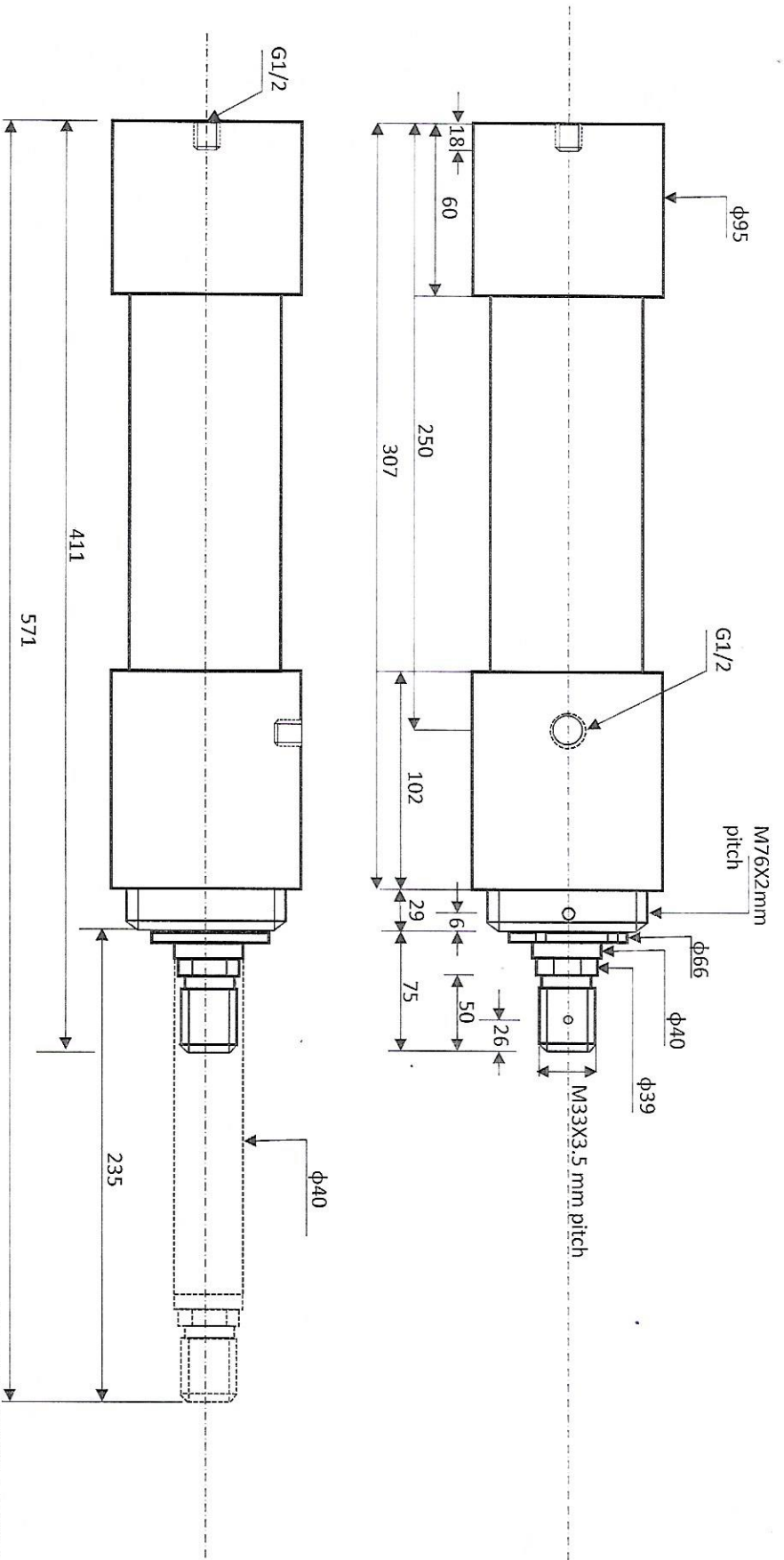

Nominal Pressure: 160 Bar

ALL DIMENSIONS ARE IN MM UNLESS OTHERWISE S

 <p>BANK NOTE PAPER MILL INDIA PRIVATE LIMITED MYSORE-570003</p>		<p>SIGNATURE</p>		<p>DATE</p>	
PREPARED BY	<i>[Signature]</i>	94/05/11	SHAFT PULLER CLAMP CYLINDER		
CHECKED BY	<i>[Signature]</i>	30/06/15	63 X 40 X 160		
APPROVED BY	<i>[Signature]</i>	30/5/16	DRG.NO:BNPM/FH/039/2017		

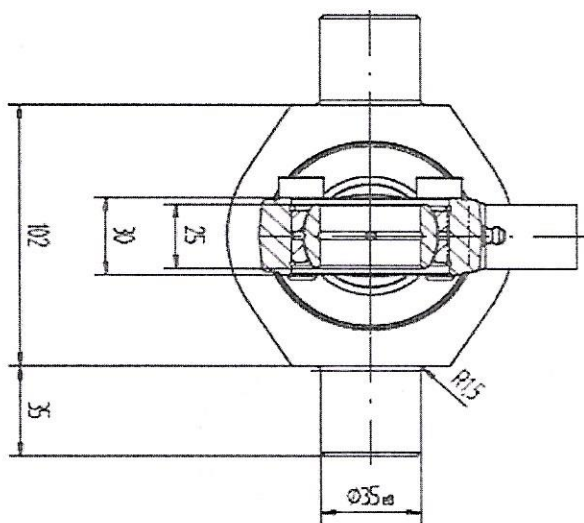
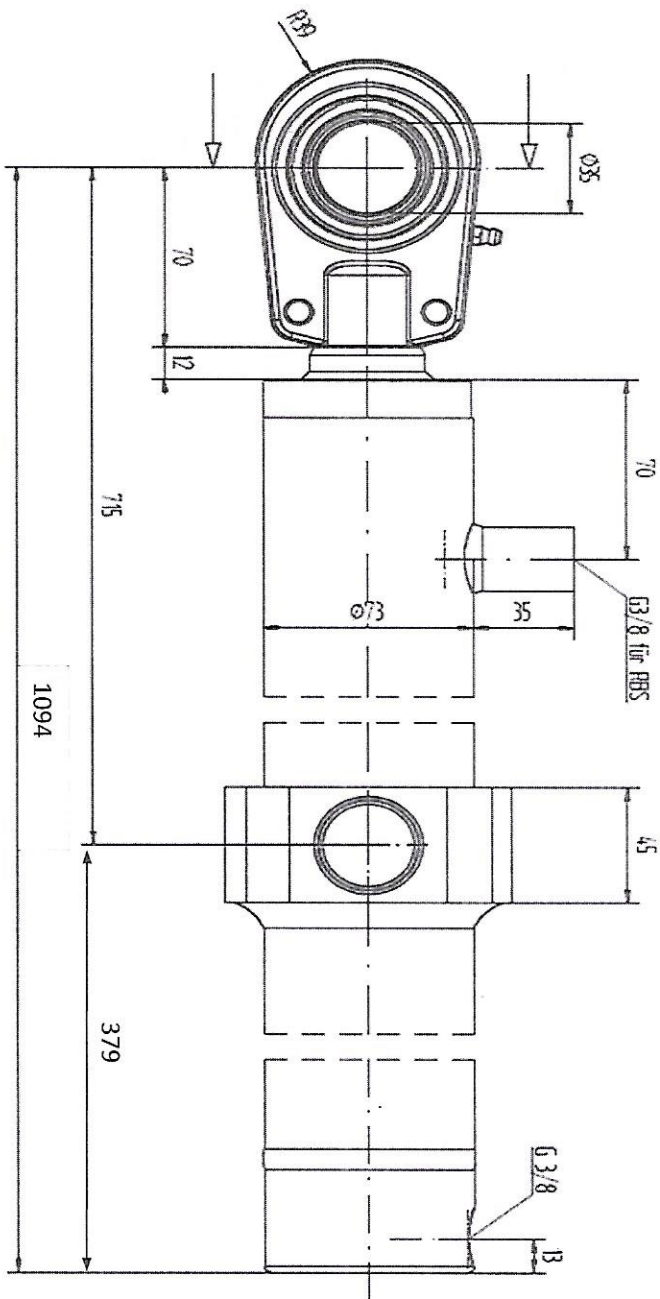

Stroke length: 850 mm
 Nominal Pressure: 160 Bar

ALL DIMENSIONS ARE IN MM UNLESS OTHERWISE SPE

 BANK NOTE PAPER MILL INDIA PRIVATE LIM <small>GENERIC COMPANY REGISTERED IN MYSORE</small> MYSORE-570003		SHAFT PULLER MAIN CYLIND 63 X 40 X 850 DRG.NO:BNPM/FH/040/201	
PREPARED BY	SIGNATURE	DATE	
CHECKED BY			
APPROVED BY			

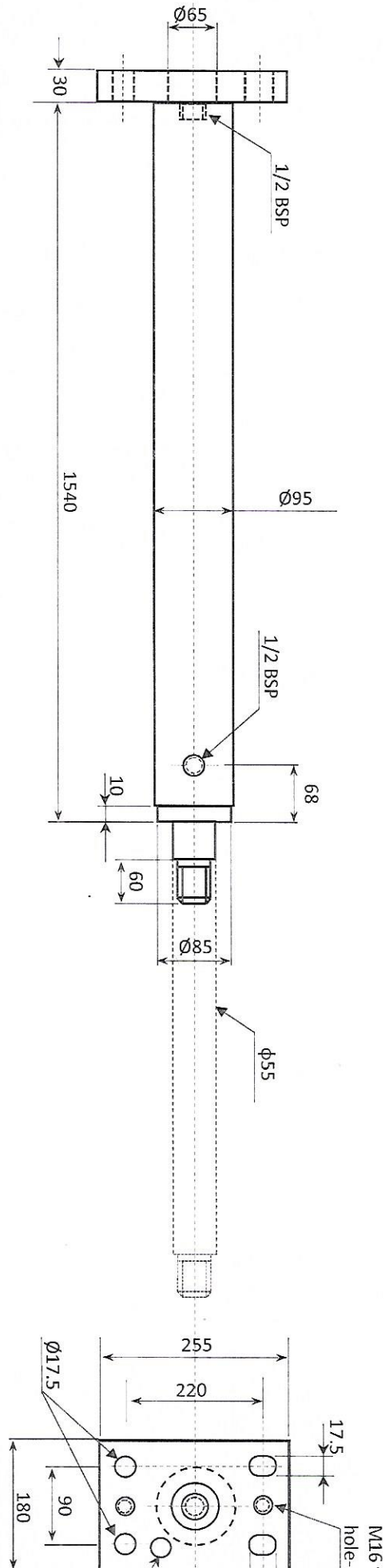
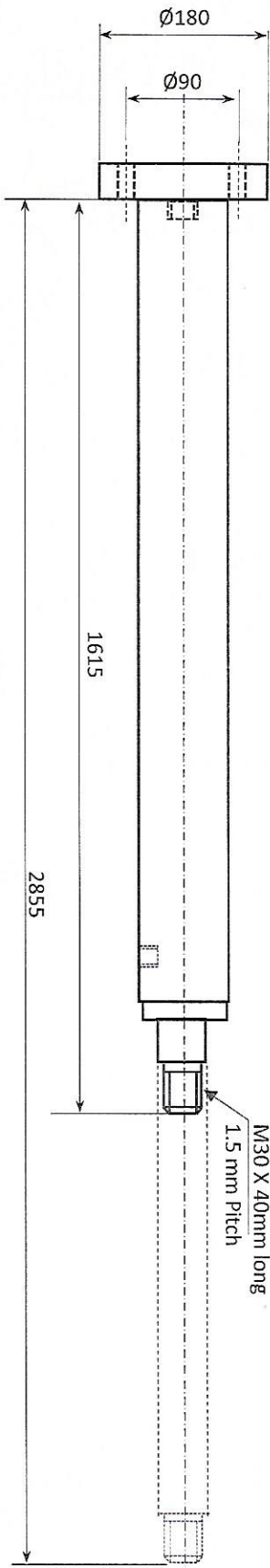

 BANK NOTE PAPER MILL INDIA PRIVATE LIMITED MYSORE-570003		SIGNATURE	DATE
PREPARED BY	<i>[Signature]</i>	<i>[Signature]</i>	<i>[Date]</i>
CHECKED BY	<i>[Signature]</i>	<i>[Signature]</i>	<i>[Date]</i>
APPROVED BY	<i>[Signature]</i>	<i>[Signature]</i>	<i>[Date]</i>
BANK NOTE PAPER MILL INDIA PRIVATE LIMITED MYSORE-570003		BALE PRESS RAM HYDRAULIC CYLINDER DRG.NO:BNPM/FH/041/2017	

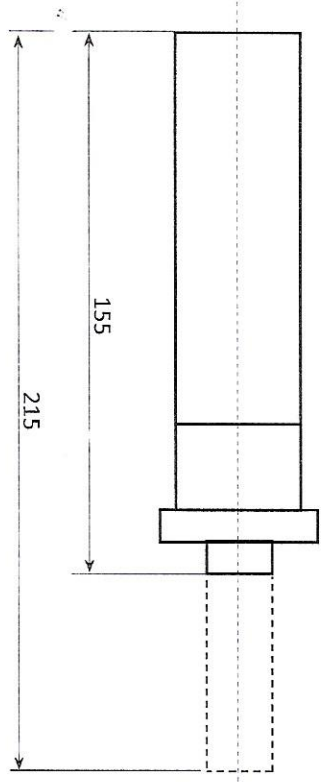
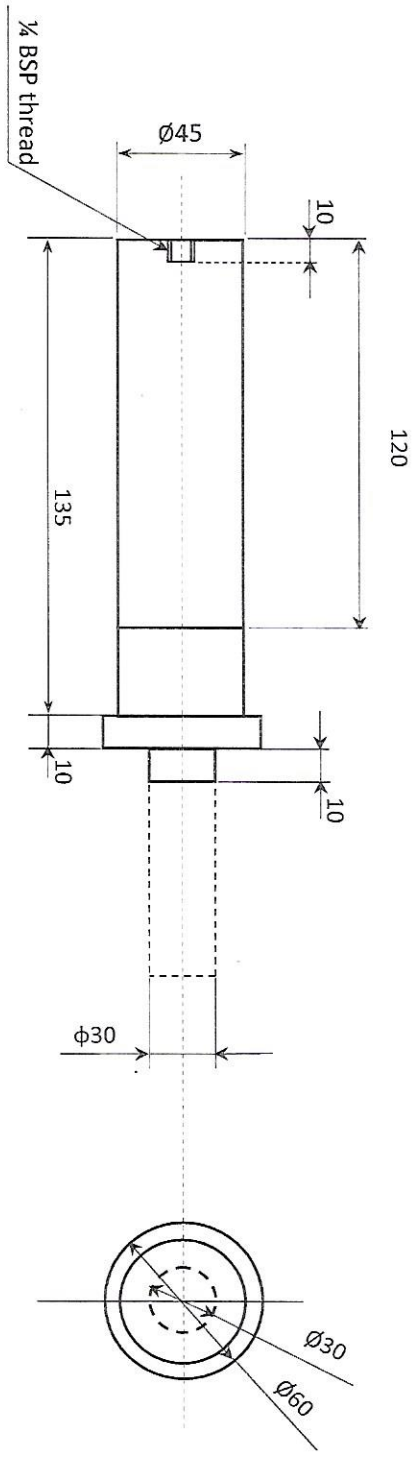

ALL DIMENSIONS ARE IN MM UNLESS OTHERWISE SPECIFIED

 BANK NOTE PAPER MILL INDIA PRIVATE LIMITED MYSORE-570003			
PREPARED BY	SIGNATURE	DATE	BALE PRESS BALE COMPACT CYLINDER DRG. NO:BNPVM/FH/042/2017
CHECKED BY	<i>[Signature]</i>	20/05/18	
APPROVED BY	<i>[Signature]</i>	20/5/18	